



Bucket Elevators
Efficiently Transport
Bulk Materials Vertically

Bucket Elevator Platforms

Bucket elevators are a highly efficient method for transporting various bulk materials vertically. The drive system is located at the top of a bucket elevator and can sometimes be several hundred feet from ground level.

KWS provides bucket elevator platforms for safe access to all sides of the head section and drive system. Platforms incorporate handrails, toe boards, guardrails, ladders, and an adjustable OSHA compliant, self-closing safety gate to create a safe and efficient working environment for personnel performing maintenance on a bucket elevator.

Features

Engineering Analysis – Platforms are analyzed using Finite Element Analysis (FEA) to ensure complete structural integrity of the design

Benefits

Safe Access – Maintenance personnel can safely and efficiently perform inspections, adjustments, and repairs

Additional Features

Ladders – Ladders provide safe access for maintenance and inspection purposes. Maintenance personnel can reach different levels such as the head, boot, and intermediate sections, to perform necessary tasks like cleaning, lubrication, and repairs. According to OSHA regulations, ladders can be up to 30 feet tall before a landing platform is required.

Fall Arrest Systems – fall arrest systems provide a means to catch an individual that might slip or fall from a fixed ladder or elevated position.

Jib Crane – Jib cranes are used to assist in lifting and lowering large replacement components, such as motors, to and from the top of the bucket elevator.



Bucket Elevators Can Sometimes Be
Several Hundred Feet Above
Ground Level

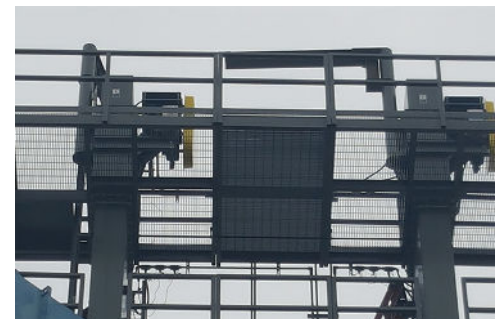

Platforms Provide Safe Access
to Head Section and Drive
System



KWS Manufacturing

3041 Conveyor Drive
Burlleson, Texas 76028

Toll Free: (800) 543-6558

Phone: (817) 295-2247

Fax: (817) 447-8528

www.kwsmfg.com



Features & Benefits

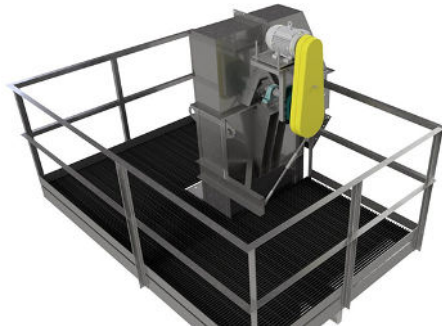

Engineering Analysis is Performed
on Every Platform

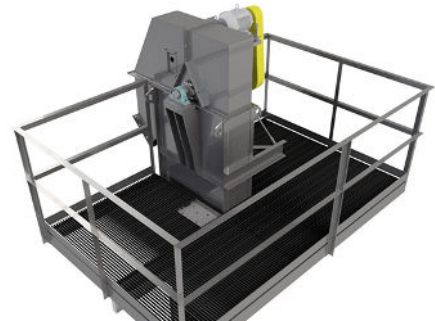

Access is Provided of All Sides
for Ease of Maintenance



Jib Cranes Assist in Lifting Heavy
Components to Head Section



KWS Manufacturing
3041 Conveyor Drive
Burlison, Texas 76028

Toll Free: (800) 543-6558
Phone: (817) 295-2247
Fax: (817) 447-8528

www.kwsmfg.com